

Morpho-Syntax Parsing*

Anna Maria Di Sciullo
Université du Québec à Montréal

Sandiway Fong
NEC Research Institute

Abstract

This paper describes an implemented bottom-up parser for a theory of morphological selection proposed in Di Sciullo (1995). Core lexical properties of derivational affixes, generally encoded in terms of subcategorization frames, are articulated in terms of asymmetrical relations. The selection of derivational affixes is couched in a uniform specifier-head-complement configuration, and predictions can be made with respect to composition and linking relation. Thus, the so-called lexical gaps fall out from the theory. Starting from a review of the underlying Asymmetry framework, the computational implications of three different implementations of this framework are discussed. In particular, the effect on bottom-up parsing from varying the specifier-head-complement order is discussed. Furthermore, computational motivation for the logical separation of overt and covert affixation is provided.

1. Introduction

We take morphological expressions to be asymmetrical [Specifier [Head Complement]] relations, where X-bar selection, in the sense of Di Sciullo (1995) holds between the affix and the root,¹ and where the Specifier, the Head, and the Complement can be overt or not. We show that the results of the implementation of X-bar selection have consequences for the optimal recovery of the morpho-syntactic asymmetries.

The organization of this paper is the following. In the first section, we present the main features of X-bar selection and show that the argument structure restrictions on morphological composition follow systematically. The second section considers different PAPPI (Fong, 1991) implementations of the theory, and provides evidence to show that the positions of the Specifier and the Complement in morphological trees as well as the separation of overt and covert processing have an effect on tractability.

2. Asymmetry

Asymmetry as a property of the structural relations derived by the grammar has been discussed mostly for syntactic expressions (Chomsky 1993, 1995, 2001; Kayne 1994, Moro 2000). The asymmetric property of morphological relation has also been discussed in Di Sciullo and Williams (1987), Di Sciullo (1996a, 1997b, 1999b, in press and forthcoming), Williams (1994), Roeper and Keyser (1995). If it is also the case that asymmetry plays a role in phonology (Rainier 2000, and in this volume), asymmetry must be a salient property of the structural relations derived by the grammar and their legibility by the performance systems.

2.1 Relations, Operations, and Conditions

Even though non-isomorphic,² morphological and syntactical expressions share a basic property, we claim that this property is asymmetry.³ More specifically, we take the configurations in (1) and (2)⁴ to be basic in the derivation of morphological expressions.

(1) [Specifier [Head Complement]]

(2)

$$\begin{array}{c} H \\ / \ \backslash \\ \text{Spec } H \\ / \ \backslash \\ H \quad \text{Compl} \end{array}$$

This is motivated as follows. First, a morphological expression includes a categorial head, as argued for in (Williams 1981) and (Di Sciullo and Williams 1987). Assuming, as in Chomsky (1995), that non-branching structures are excluded by minimalist assumptions and that each head has one complement, head-complement relations are part of morphological expressions. Second, assuming that a head-complement relation must be included in a specifier-head relation to be complete, a morphological expression is an asymmetrical structure.⁵ As derivational morphology affects not only the categorial features of a root but also the argument features of both the root and the affix, and given a configurational representation of argument structure, the [Specifier [Head Complement]] configuration is part of the derivation of morphological expressions. Fourth, the asymmetric [Specifier [Head Complement]] structure in morphology is motivated by the Universal Base Hypothesis (Kayne 1994), according to which the order of the base constituents is universally the following: the Specifier precedes the Head, and the head is followed by Complement. Thus, there are theoretical justification to the hypothesis that asymmetrical relations are part of the derivation of morphological expressions.

We assume that the grammar includes structure building and linking operations. The first operation derives complex categories on the basis of more elementary ones; the second operation relates features in derivations and representations. It ensures that the linked categories are identical in reference.

We also assume that the operations of the grammar are relativized to the sort of derivation.⁶ Thus, for the derivation of morphological expressions, we have:

- (3) Selection: An affix head projects an X-bar structure and combines with the full asymmetrical projection of a root by selecting an Argument feature of the Specifier or the complement of that projection. (Di Sciullo 1995: 87)
- (4) Linking : Every non-argument feature ($\neg A$) must be A-linked; Every argument features (A) may be A-Linked. (Di Sciullo 1995: 89)

The tree in (5), where H is an affixal head and R is a root is obtained from the first operation. The second operation relates non Argument ($\neg A$) to Argument (A) feature positions distributed in the Spec and Compl positions.

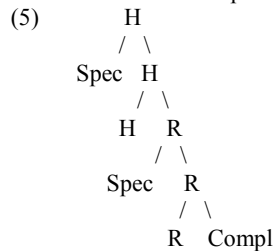

Thus, the operations and conditions preserve the basic asymmetric nature of morphological elements, affixes and roots. The next section brings some empirical evidence to this theory.

2.2 Coverage

There is evidence to the effect that an asymmetry-based theory makes more accurate predictions than other theories of morphology with respect to the combinatorial restrictions imposed by affixes on roots. It also provides a rationale as for why these restrictions do exist. Thus, its explanatory capacity extends beyond morphological theories not based on asymmetry.

2.2.1 Category Changing Suffixes

We correctly predict that derivational category changing affixes combines with roots according to their asymmetric A-structure properties. Thus, the nominal suffix *-er* combines with unergative and transitive verbs, but not with unaccusative verbs. The nominal in (6a) is based on an unergative verb, that is a verb that takes an external argument but no internal argument; the nominal in (6b) is based on an unaccusative verb, that is a verb that takes an internal argument but not an external argument.

- (6) a. This student is a dreamer.
 b. *Trains are arrivers.

These restrictions do not follow from theories where morphological composition is based on categorial selection, as it is the case in Grimshaw (1990), Lieber (1992), Anderson (1992), and Law (1997). The complement domain of a head is not accessible to categorial selection, which is restricted to sisterhood.

Furthermore, the fact that the nominal suffix *-er* combines with unergative verbs, as in (6a), as well as with transitive verbs, as in (7), indicates that the restrictions on morphological composition are not thematic restrictions, as the external argument of an unergative verb is not an Agent, whereas it can be in the case of a transitive verb.

- (7) a. the rider on the shore
 b. the fighters in the ring

The restrictions on morphological composition are based on asymmetrical relations, such as the presence of an A-spec relation in the complement domain of the affix, as depicted in (8).

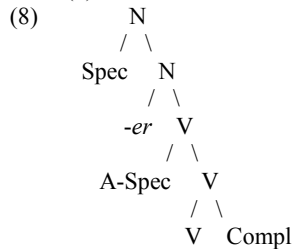

The fact that the nominal affix may combine with unergatives and transitives but not with unaccusatives constitutes evidence that the morphological composition is based on asymmetrical relations.

There are further restrictions to the composition of the nominal affix *-er* with a verbal root. The examples in (9) illustrate the fact that the nominal affix may not combine with the obligatory ditransitive verb *put*, while it may do so with *send*, which is also ditransitive but does not require the obligatory presence of the prepositional complement.

- (9) a. *the puter of the letter in the mail
 b. the sender of the letter

Morphological composition is thus restricted by specific asymmetrical relations, which prevent an affix, here the nominal affix *-er*, from combining with certain configurations, here with verbal projections including two internal arguments.

This situation is not restricted to nominal affixes, but obtains across the board for derivational affixes, irrespective of their categorial features. Thus, the configurational asymmetry with respect to morphological composition can be observed with adjectival as well as verbal affixes, as well as with nominal affixes.

Thus, the adjectival suffix *-able* combines with a transitive verb, whether the verb has an agent or not as its external argument, as illustrated in (10a). However, it does not combine with the obligatory ditransitive *put*, as exemplified in (10b). Thus, here again, as is the case for the nominal affix *-er*, morphological composition is restricted by asymmetrical relations. In the case of *-able*, there are additional restrictions, as the affix may not combine with unergative or unaccusative verbs. This is exemplified in (10c) and (10d).

- (10) a. a desirable and affordable book
 b. *a putable book on this shelve
 c. *a sitable chair
 d. *a leaveable place

This is expressed in the following tree, where both the Specifier and the Complement of the verbal root are argumental.

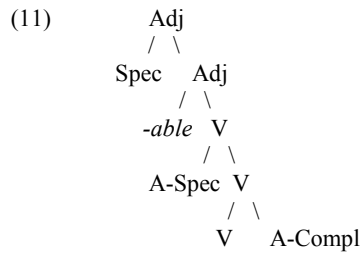

Verbal suffixes are not immune to restrictions with respect to morphological composition. Thus, the verbal suffixes *-ify* and *-ize* may combine with intransitive predicates, but not with transitive ones, as depicted in (12). The restrictions are illustrated in (13), where the verbal affix combines with an adjectival or a nominal projection (Adj/N).

- (12) a. a formalized theory
 b. a computerized accounting system
 c. *This equalizes the results.
 d. *It's hard to friendize with him.

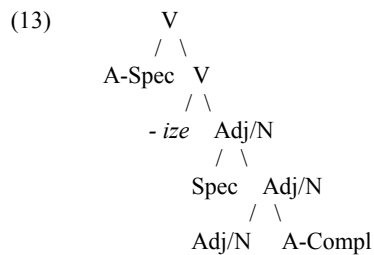

Given a configurational representation of argument structure, it is possible to account for the restrictions on the combination of affixes and roots which cannot be accounted for by morphological theories based on symmetrical categorial-selection for derivational affixes. In our view, an affix projects an asymmetrical structure and selects an asymmetrical structure. Affixes differ with respect to the specific argument structure requirement they impose on the configuration they combine with, as summarized in (14) and (15):

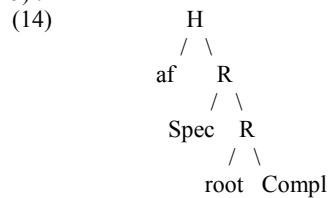

- (15) a. (A-Spec) : *-er*
 b. (A-Compl) : *-ize, -if*
 c. (A-Spec, A-compl) : *-able, -ee, -ive*

Thus, the structure-building operation combining affixes and roots applies to objects that are asymmetrical relations; it does not apply to unstructured objects. It is restricted by the configurational asymmetries of the elements undergoing the operation. That asymmetrical relations override categorial-selection in derivational morphology is expected in our theory, which is based on the hypothesis that asymmetric relations are basic in grammar.

Furthermore, argument features are projected in asymmetrical configurations and are subject to morphological Linking. Morphological Linking determines what parts of a root are affected by an affix, how the argument structure projected by an affix is used up, as well as it provides a rationale to the asymmetrical nature of selection in derivational morphology. The following illustrates this point.

The verbal affixes *-ize* and *-ify* both project an A-Spec (external argument). Consequently, they may only combine with roots that lack an A-Spec, as there can be only one external argument per projection. Thus, in (16a) the verbal suffix *-ify* projects an A-spec and thus may Shift with an adjective that lacks an A-spec. The example in (16b) shows that the verbal suffix cannot Shift with an adjective that projects an A-Spec.

- (16) a. a simplified problem
 b. *an enviousified neighbor

Adjectival suffixes affect the argument structure of the verbal projection with which they combine. The complement of the verbal projection is the Specifier of the *-able* adjective used predicatively. The A-spec of the verbal projection is the Specifier of the *-ive* adjective used predicatively. As such, the latter cannot combine with an unaccusative, and the former with an unergative.

- (17) a. This puzzle is solvable (*of/by anybody).
 b. *Rain is fallable.
 c. Unicorns are impressive (*of/for people).
 d. *Gentlemen are standable in trains.

Nominal affixes affect the argument structure of the verbal projections with which they combine. The complement of an *-er* nominal is the complement of the verbal base, whereas in the case of an *-ee* nominal, it is the specifier of the verbal base. These nominal affixes cannot combine with verbs that do not project both an A-Spec and an A-Compl, as the following examples illustrate :

- (18) a. The adviser of Paul (*by John).
 b. The advisee of John's (*of Paul).

- (19) a. *This is the shiner and that is the shinee.
 b. *Paul is the departer and Luc the departee.

Thus the asymmetric property of morphological relation, expressed in terms of the [Specifier [head Complement]] structure, plays a role in derivational morphology. It plays a role with respect to Morphological Selection as well as with respect to Morphological Linking.

2.2.2 Prefixes

Asymmetrical relations are also crucial in the derivation of prefixed forms. In the languages under consideration, contrary to a suffix, a prefix does not directly determine the category of the projection it is a part of. Certain prefixes can be associated with a root, irrespective of the lexical category of that root, as in (20), where they do not affect the categorial features of the root.

- (20) a. John unfolded the map. (*fold*: V)
 b. This behavior is unwise. (*wise*: Adj)

Moreover, in some cases, the association of a prefix with a root is independent of the properties of the complement domain of that root, as illustrated in (21) and (22) with French data.

- (21) a. Jean est accouru. (*courir* 'to run' unergative)
 'John ran up.'
 b. Paul a apporté la mallette. (*porter* 'to carry' transitive)
 'Paul brought the case.'
- (22) a. Luc est retombé du lit. (*tomber* 'to fall' ergative)
 'Luc fell from his bed.'
 b. La bague a rebrillé. (*briller* 'to shine' unergative)
 'The ring shined again.'
 c. Marie a relu la phrase. (*lire* 'to read' transitive)
 'Mary reread the sentence.'
 d. Sophie a remis la tortue dans l'aquarium. (*mettre* 'to put' ditransitive)
 'Sophie put the turtle back into the aquarium.'

In the example in (21a), the internal directional prefix *a-* combines with the unergative *courir* 'to run' and, in (21b), it combines with the transitive verb *porter* 'to carry'. The examples in (22) are cases of external prefixation. They illustrate the fact that the iterative prefix is not sensitive to the argument structure properties of the verbal projection it combines with. It combines with an unaccusative in (22a), with an unergative in (22b), with a transitive in (22c), and with a ditransitive in (22d).

We showed that prefix selects on the basis of aspectual properties (Di Sciullo 1996a ; Di Sciullo 1997b); (Di Sciullo and Tenny 1997)). Directional and Locational prefixes may add a terminus to the event denoted by the predicate they adjoin to. Thus, they may only adjoin to predicates that are underspecified for a terminus. This is the case for subset of predicates denoting activities, including *courir* 'to run' and *apporter* 'to bring'.

Thus, it appears that prefixes are different from suffixes with respect to Selection. Prefixes Select on the basis of aspectual features. They are also different with respect to Linking. While category-changing suffixes determine the restrictions on Argumental

linking, prefixes determine the restrictions on Aspectual linking. A prefix may restrict the aspectual features of the category it is associated to either within the minimal argument structure projection of that category, as depicted in the partial structure in (23), or outside of this domain, as depicted in the partial structure in (24). The first situation arises with directional and locational prefixes, the second situation arises with iterative, inverse, and evaluative prefixes.

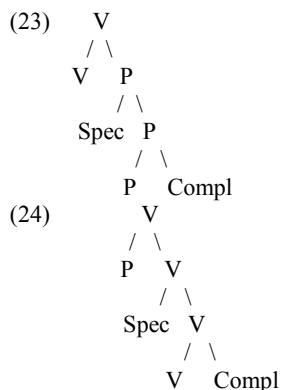

The configurational difference between internal and external prefixes is expected within the theory, as the properties of a prefix follow from the asymmetric domain it is a part of. We will be concerned here with the first sort of prefixes only, that is with the internal ones, and we will not consider external prefixes.

2.2.3 Phonetically Null Positions

The elements that participate in the asymmetrical relation may lack phonetic features, but not semantic features. This is the case for the Spec and the Compl in the derivations of the morphological expressions discussed in section 2.1. The covert Spec and Compl have no phonetic feature, but they do have Argument features. Otherwise, it could be impossible to account for the configurational argument structure restrictions on the combinations of affixes and roots. For example, in (25a) the Spec of the base verb *break* in *breakable* is covert, whereas in (25c), it is the Compl of the base verb *impress* in *impressive* that is covert. The covert Spec and Compl in morphology are not equivalent to covert elements in syntax, such as copies and abstract pronouns, as the projection of covert Spec and Compl positions in morphology is determined exclusively by the argument features of the morphological head they are dependent on.

- (25) a. Murano jars are breakable.
 b. Burano laces are sellable.
 c. The guards are impressive.
 d. This proposition is attractive.

Morphological expressions may also include covert heads. This can be seen by contrasting the English denominal verbs with no overt verbal head in (26) with the equivalent French forms in (27), as well as by comparing the English examples in (28) with no overt prepositional with (29):

- (26) a. Mary likes *to send* mail to her friends in the morning.
 b. Paul prefers *to butter* bread with a spoon.
 c. Luc suggests *to nail* R2V2 to the ship.
- (27) a. Mary aime *poster* des lettres à ses amis le matin.
 ‘Mary likes to send letters to her friends in the morning.’
 b. Paul préfère *beurrer* le pain avec une cuillère.
 ‘Paul prefers to butter the bread with a spoon.’
 c. Luc suggère de *clouer* R2V2 au vaisseau.
 ‘Luc suggests to nail R2V2 to the ship.’
- (28) a. John *stored* the books.
 b. Lucy *bottled* the potion.
 c. Marc *cash*ed the check.
- (29) a. John a *enmagasiné* les livres.
 ‘John stored the books.’
 b. Lucy a *embouteillé* la potion.
 ‘Lucy bottled the potion.’
 c. Marc a *encaissé* le chèque.
 ‘Marc cashed the check.’

The argument structure projection⁷ for English denominal and deadjectival verbs includes covert suffixes and prefixes in some cases, whereas in French these elements are overt. In the structure in (30a), for French denominal verb *encaisser* ‘to cash’, the causative [CAU] verb is morphologically spelled out by the verbal suffix *-er*, the change of state/position inchoative [INC] verb is covert. The directional/locational prefix *en-* heading the resulting change of state/position constituent, the terminus of the event, is overt. In (30b), for the French deadjectival verb *embellir* ‘to become more beautiful’ or ‘to make someone become more beautiful’, the causative affix is null and the inchoative verb is spelled out by the suffix *-ir*. In both cases the prefix is overt, whereas in the equivalent in English examples the prefix is covert. The variation between languages reduces to a difference in the strength of a subfeature of Aspect, as proposed in (Di Sciullo 1999a).

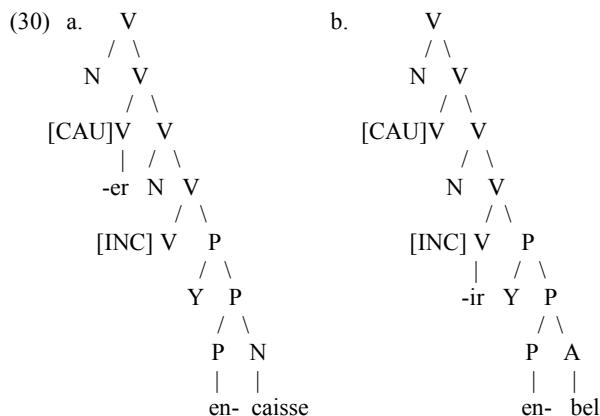

Thus, covert Heads as well as covert Spec and Compl are part of derivations of morphological expressions.

While [Spec [Head Compl]] relations are required because of the asymmetric property of morphological relations, the overt or covert nature of the members of these relations is a consequence of language specific feature specification.⁸

2.3 Summary

We brought further justifications to a theory that derives complex morphological expressions on the basis of the asymmetrical relations of their parts. The theory achieves greater descriptive and explanatory adequacy than theories based on categorial-selection and theta-grids. It also provides a systematic analysis of formal (categorial) and semantic (argument and aspect) features in derivational morphology.

3. Three Parsing Models

Linguistic theory often provides enough freedom for a variety of different computational models to be tested. Whilst remaining faithful to the theory, from a computational perspective, we are also interested in improving the efficiency of parsing models. The contribution of particular elements of a theory to computational complexity can be determined through experimentation. In particular, we will discuss the effects of variation in Specifier-Head-Complement order, and the contribution of empty heads and prefixes to the complexity of morphology within the framework of bottom-up shift-reduce parsing.

3.1 Background

In this section, we describe, in turn, the encoding of X'-structure, the lexical representation of morphemes and heads, and the implementation of the Linking constraint.

3.1.1 X' Structure

We assume heads uniformly project two-level X' structure, as shown in (31):

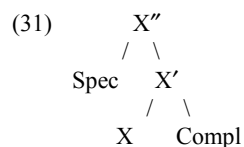

The corresponding context-free X' grammar is shown in (32):

- (32) **rule** $XP \rightarrow [X1, YP]$ **st** $\text{max}(XP), \text{bar}(X1), \text{proj}(X1, XP), \text{max}(YP)$.
rule $X1 \rightarrow [ZP, X]$ **st** $\text{bar}(X1), \text{head}(X), \text{proj}(X, X1), \text{max}(ZP)$.
rule $xp \rightarrow []$.

X, X1, and XP are logical variables ranging over category labels at the head, bar, and maximal projection levels respectively. Heads will be grounded in the lexicon. Maximal projections YP and ZP will be realized recursively as either X'-structures or as a special maximal projection x_p introduced by the empty category rule shown above. The relevant categories and the projection relation are defined below:

```
(33) head(n) . head(v) . head(a) . head(p) .
      bar(n1) . bar(v1) . bar(a1) . bar(p1) .
      max(np) . max(vp) . max(ap) . max(pp) . max(xp) .

      proj(n,n1) . proj(v,v1) . proj(a,a1) . proj(p,p1) .
      proj(n1,np) . proj(v1,vp) . proj(a1,ap) . proj(p1,pp) .

      head(n1,n) . head(v1,v) . head(a1,a) . head(p1,p) .
      head(np,n) . head(vp,v) . head(ap,a) . head(pp,p) .
```

A LR(1) – based parser was adopted for analysis. LR(1)-parsing, (Knuth 1965) is a well-known and highly-efficient method of shift-reduce (bottom-up) parsing that processes morphemes in a left-to-right manner using a single symbol of lookahead for local disambiguation.⁹The adopted algorithm relaxes the strict LR(1) requirement of zero conflicts by allowing shift/reduce and reduce/reduce conflicts to exist in the table. Conflict resolution is handled by backtracking in the underlying Prolog system (Fong 1991).

3.1.2 The Lexicon

The lexicon uses a default feature system for lexical entries. The following declaration expresses the lexical defaults for nouns, verbs, and adjectives:

```
(34) default_features([n,v,a],[specR(f(a(-))),selR(f(a(-)))]).
```

In (34), `specR` imposes restrictions on Specifier positions, and `selR` on Complement positions. `f(a(-))` indicates that the referenced position should have feature `a(-)`. By convention, A/A-bar-positions are encoded using `a(±)`. Hence, by default, Specifiers and Complements are A-bar-positions (unless otherwise indicated).

Consider the nouns in (35). By default, *computer* has two A-bar-positions. *Form* and *father*, on the other hand, have one and two A-positions, respectively.

```
(35) lex(computer, n, []).
      lex(form, n, [selR(f(a(+)))]).
      lex(father, n, [specR(f(a(+))),selR(f(a(+)))]).
```

Affixes impose constraints on their Complement domain. For example, the nominal affix *-er*, e.g. as in *employer*, in (36), indicates that the Specifier of its complement must be an A-position. Similarly, *-ee*, e.g. as in *employee*, restricts both the Specifier and Complement *within* its Complement to be A-positions.

```
(36) lex(er,n,[link(spec),selR(spec(f(a(+))))]).
      lex(ee,n,[link(compl),selR([spec(f(a(+))),compl(f(a(+)))])]).
```

Finally, the abstract causative morpheme, *caus* in (37), differs from the inchoative *inc* in terms of selection in that it has an A-Specifier as well as restricting the Specifier of its Complement to be an A-bar-position.

```
(37) lex(caus, v, [specR(f(a(+))), selR(spec(f(a(-))))], caus) .
      lex(inc, v, [link(compl), selR(spec(f(a(-))))], inc) .
```

The *-er*, *-ee*, and *inc* morphemes have an additional feature `link(spec/compl)`, which specifies the target of A-bar-Specifier Linking in a complement domain. We discuss the role of this feature in the next section.

3.1.3 Linking

There is a single free-standing principle that encodes the following rule:

(38) **Linking Rule:** All Affix A-bar-positions must be linked to A-positions in their Complement domain (if one exists).

This is implemented by the universally-quantified (over tree structure) condition `linkR` shown in (39):

```
(39) linkR in_all_configuration CF where
      linkConfig(CF, XP, Type, Dom)
      then findApos(YP, Type, Dom), coindex(XP, YP) .

linkConfig(CF, XP, Type, Dom) :-
  maxProj(CF), CF has_feature link(Type),10
  XP specifier_of CF, \+ XP has_feature a(+),
  Dom complement_of CF.
```

This definition looks for configurations meeting the requirements of `linkConfig`: i.e. CF must be a maximal projection with an A-bar-Specifier XP and a Complement Dom. For all satisfying configurations, `findApos` (definition not shown) will extract a phrase YP occupying an A-position of the appropriate sort indicated by Type. Here, Type refers to a lexical feature `link` and will be either `compl`, as in the case of *-er* in (36), or `spec`, as in the case of *-ee* and *inc* in (36) and (37), respectively. The resulting linking relation between XP and YP is indicated via coindexation.

All parses assigned an X'-structure will be filtered using this rule. If a linking configuration can be found, i.e. some maximal projection with an A-bar-Specifier that needs to be linked exists, but `findApos` fails to report an A-position of the appropriate type, the parse will be rejected.

3.2 Specifier-Head-Complement Asymmetry

In this section, we consider the computational consequences of varying the Specifier-Head linear order for the LR shift-reduce parsing framework, i.e. (40a) vs. (40b) below:¹¹



(a) Specifier on the left

(b) Specifier on the right

It turns out there is a considerable difference both in terms of the number of LR actions performed and the stack depth required to process an example like *formalize*, analyzed as *form-al-i(z)-e* in (41) below:

(41)

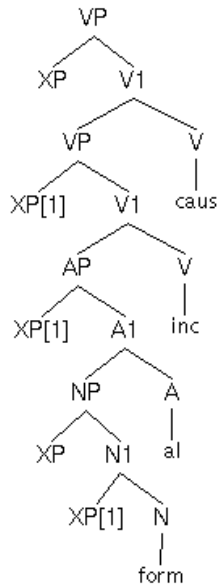

LR Actions: 96

(a) Formalize with Left Specifier

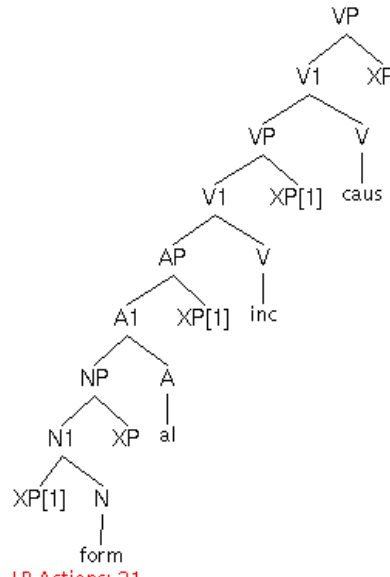

LR Actions: 21

(b) Formalize with Right Specifier

The simple explanation is that the LR machine has to be able to predict an arbitrary number of empty argument positions before it can shift or "read" the first item, namely *form*, in (41a).¹² Contrast this with the situation in (41b), where Specifiers are generated on the right side only. Here, the LR machine needs only to generate a single empty argument position before a shift can take place. Hence only 21 actions and a stack depth of 2 are required in this case, compared to 96 and a stack depth of 5 in (41a). The following table compares left and right Specifiers for a variety of examples:

(42)

Word	Items	LR actions	
		Left Specifier	Right Specifier
form	1	8	6

read-able	2	19	11
simpl(e)-i(f)-y	3	47	16
form-al-i(z)-e	4	96	21
form-al-i(z)-(e)-able	5	172	26

Finally, note that the right Specifier model is *nearly* optimal in terms of the minimum number of actions required to analyze each word.¹³ In general, the minimum number is given by the formula $4i+2$, i being the number of items in the analysis of the word.¹⁴

3.3 Empty Heads and Prefixes

In this section, we describe the implementation and discuss the computational consequences of introducing empty heads and prefixes into the system.

3.3.1 Empty Heads

English has both zero and non-zero $N \rightarrow V$ conversion:

- (43) a. John bottled the wine
 b. Mary computerized the accounting department

In (43b), *computerize* is analyzed as the noun *computer* followed by the suffix *-ize*, which is, in turn, further decomposed into *-i(z)-e*, where the two constituents are merely instantiations of the (abstract) inchoative and causative morphemes, shown earlier in (37). As (44) indicates, we can analyze *bottle* along the same lines:

(44)

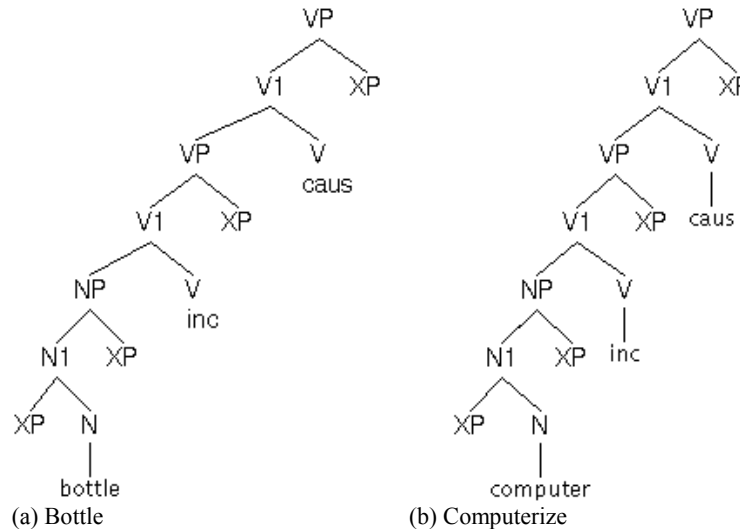

That is, the only difference with *bottle* as a verb is that the inchoative and causative morphemes are zero affixes. This is implemented by the following empty verb rule, defined to take on features from either abstract *caus* or *inc*:

```
(45) rule v with Fs → [] st emptyVFs(Fs) .
      emptyVFs(Fs) :- causative(Fs) .
      emptyVFs(Fs) :- inchoative(Fs) .
```

Unlike the case of empty specifiers or complements, empty heads generally permit infinite recursion, and therefore, an endless number of parses for any word. We can address this in the case of *inc* and *caus* by appealing to semantic considerations: that is, they can occur at most once per singular event. This constraint is imposed by the following declarations:

```
(46) unique_feature_domain max .
      inc unique_feature_in max .
      caus unique_feature_in max .

      top(max) . % LR machine declaration
```

The topmost (dummy) node returned by the LR machine, named *max*, is defined to be the domain for features *inc* and *caus*, which are declared as unique features, and therefore may be inserted at most once in *max*, thus guaranteeing parsing termination.¹⁵

3.3.2 Empty Prefixes

There is reason to assume that a covert directional prefix is present in the structure for *bottle* as a verb:

- (47) a. embouteiller (French)
 b. imbottigliare (Italian)
 c. (to) bottle

Here, *bottle* represents the final location of an object that is the target of the event. The directional prefix, call it *en-*, will identify or supply an A-position that is necessary for the proper linking of the A-bar-Specifier of *inc*. Similarly, *en-* is also required in the case of the verb *computerize*. The role of *en-* as a prefix is made explicit in the following parses:

(48)

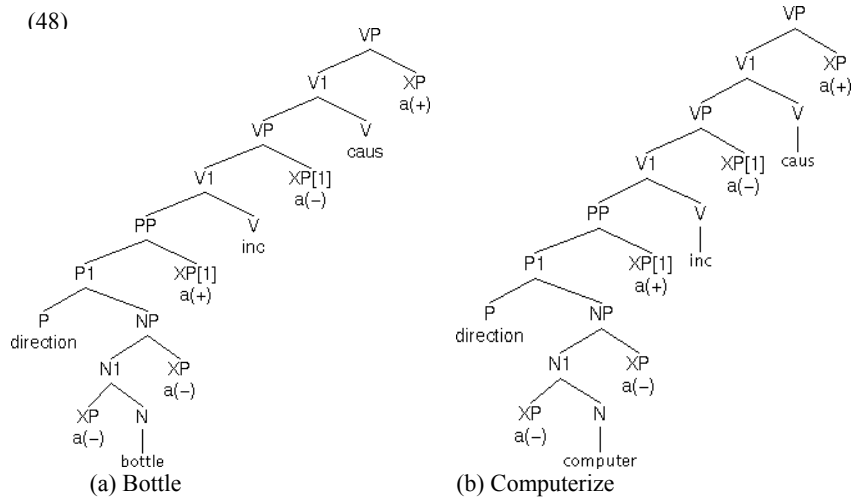

In (48a-b), the covert directional prefix selects for a phrase headed by *bottle* and *computerize*, respectively. This is implemented by adopting the following rule:

(49) `rule p with Fs → [] st en(Fs) . % See lexical entry for en-`

The empty preposition defined in (49) references the lexical entry for *en-* in (50):

(50) `lex(en, p, [direction, specR(f(a(+))),
selR([spec(f(a(-))), compl(f(a(-)))])]) .`

`direction unique_feature_in max.`

This basically states that *en-* is a directional preposition that supplies an A-Specifier and selects for a (locative) Complement phrase containing no A-positions, as is the case with *bottle* and *computerize*. As the indexation in (48a-b) indicates, the A-bar-position associated with *inc* links to the A-position provided by *en-*.

Finally, *direction* is declared as a unique feature for both semantic and termination reasons, as in the cases of *inc* and *caus* described earlier.

3.3.3. A Two-Stage Model

The expansion of the LR(1) parsing engine to account for empty heads and prefixes actually resulted in a decrease in machine size from 117 to 71 states as shown in (51):

(51)

Machine	States	No conflict	Single conflict	Multiple Conflicts
Standard LR	117	371 63%	214 37%	0 0%
Plus empty heads/prefixes	71	145 41%	64 18%	146 41%

However, it is important to realize that a smaller machine does not necessarily mean a more efficient parser. The distribution of LR action conflicts provides a strong indication that the revised machine is computationally much less tractable. For instance, the number of state/lookahead pairs is split 2:1 in the case of the standard machine, with only a third of them registering a single conflict, i.e. there are two possible LR actions to choose from. Contrast this with the revised machine which has a substantial proportion of multiple conflicts (40%), i.e. computational choice points with three (or more) possible LR actions. This is borne out empirically as (52) attests:

(52)

Example	LR Actions	
	Single-Stage	Two-Stage
form	53	7
bottle	80	7
readable	75	12
simplify	91	18
computerize	139	18
formalize	147	23
formalizable	157	27

Here we have two competing parsing engines: (A) a single-stage LR machine, containing both overt and non-overt heads and prefixes, and (B) a two-stage engine consisting of a simplified (overt only) LR machine, followed by a second, separate stage, responsible for adding back in any empty heads or prefixes.¹⁶ By comparing the results of the two-stage engine against those shown earlier in (42), it should be clear that dividing up the computational burden up into two separate modules is a strategy that permits us to handle zero morphology in an efficient manner.

4. Consequences and conclusions

This work has consequences for the properties of the grammar, the properties of the parser, and their interface. The results of the implementation bring evidence to the effect that the grammar and the parser are different systems. The grammar optimally derives asymmetrical relations in the Specifier-Head-Complement format. The parser optimally recovers asymmetrical relations where the basic relations are inverted. This cannot be otherwise as the grammar and the parser are two different systems. The grammar is a model of linguistic knowledge and the parser is a model of linguistic use. The systems may

interface because of the asymmetrical properties of structural descriptions generated by the grammar.

We have provided further theoretical and empirical motivations for the projection of asymmetrical Specifier-Head-Complement structure in the derivation of words. This follows in a principled way from the theory. The implementations of this theory provided strong computational motivation for both Specifier-right, Complement-left pairing of X' structure and for the separation of overt and non-overt affix heads into distinct modules.

Notes

* This work is supported in part by funding from the Social Sciences and Humanities Research Council of Canada to the Asymmetry Project, grant number 214-97-0016, and by the NEC Research Institute.

¹ The asymmetric properties of morphological relations are discussed at length in a forthcoming book by the first author entitled *Asymmetry in Morphology* from MIT Press.

² See Di Sciullo and Williams 1987 ; Di Sciullo 1996a; Bach 1996; Williams 1994, among others for arguments motivating the non-isomorphy of morphological and syntactic derivations.

³ We assume that a relation is asymmetric in a set A if for each ordered pair (x, y) , there is not (y, x) that is also part of A . Asymmetric c-command is the typical relation that satisfies the property of an asymmetric relation in grammar. x asymmetrically c-commands y iff x and y are categories, and x excludes y , and every category that dominates x dominates y . (Kayne 1994:16)

⁴ The configuration in (2) does not include bar levels, such as XP , X' and X , as in the standard X-bar notation. We will assume that maximal and minimal categories are identified configurationally, as in Chomsky (1993), where a minimal category projects whereas a maximal category does not project anymore.

⁵ The [Specifier [Head Complement]] configuration plays a crucial role in the derivation of the argument structure properties of morphological expressions, given a configurational representation of argument structure. See Chomsky 1993, 1995,1999; Di Sciullo 1993, 1995; Hale and Keyser 1993, Pesetsky 1995, and related works on configurational representation of argument structure.

⁶ The architecture of our Model is defined in (Di Sciullo 1996b) and is based on the following hypothesis. According to the *Modularity of Computational Space*: The computational space includes interacting types of derivations leading to optimal target types of configurations. According to *Relativized Modularity*: The principles of the grammar apply to types of derivations and interfaces according to their optimal target configurational properties. The differences between morphological and syntactic asymmetries follow in a principled way from the sort of grammatical derivations.

⁷ The XP argument structure projection is not isomorphic to the X⁰ structure projection, interpreted at PF, deriving the linear order properties of morphological objects.

(i) [en caisse_P] -er_V] (ii) [en bel_P] -ir_V]]

See Di Sciullo (1997a,b) and Di Sciullo forthcoming for discussion.

⁸ See Di Sciullo (1999a, and forthcoming) for discussion on morphological variation.

⁹ The small size of the grammar permits the adoption of full LR(1)-style parsing. The machines described here have of the order of about 100 states.

¹⁰ Features of the head such as link are also available at the maximal projection level.

¹¹ By flipping the linear order of the head and complement, two other specifier-head-complement configurations can be obtained. Here, we fix the head as being to the right of the complement for reasons of linearization.

¹² This is a form of infinite looping. In the implementation, the amount of looping is controlled by a runtime adjustable limit on the number of consecutive empty categories that can be pushed onto the stack.

¹³ More precisely, the right specifier model “garden-paths” for exactly one action at a particular shift/reduce conflict point for every affix. A more detailed analysis is beyond the scope of this paper.

¹⁴ A quick breakdown of the formula is in order here: to produce a two-bar-level structure, 2 reduce actions forming X' and X'' are required, plus another one for the xp specifier and a shift for the head. So the total is 4 per “phrase”. The “plus 2” part of the formula comes from the accept and lowest complement xp reduce actions.

¹⁵ PAPPi implements the efficiently by checking for duplicates immediately at abstract affix insertion time.

¹⁶ The second stage actually consists of two smaller sub-modules, one responsible for inc and caus which runs in constant time, and the other for internal prefixes such as *en-*, running in time proportional to the depth of the parse.

References

- Anderson, S. 1992. *A-Morphous Morphology*. Cambridge, Mass.: Cambridge University Press.
- Bach, E. 1996. “On the grammar of complex words”. In *Configurations*, A.-M. Di Sciullo (eds), Cascadilla Press.
- Borer, H. 1991. “The causative-inchoative alternation”: A case study in parallel morphology. *The Linguistic Review* 8.
- Chomsky, N. 1993. “Bare phrase structure”. Cambridge, Mass.: MIT Press.

- Chomsky, N. 1995. "The Minimalist Program". Cambridge, Mass.: MIT Press.
- Chomsky, N. 1998. "Minimalist Inquiries". Ms. Cambridge, Mass.: MIT Press.
- Chomsky, N. 1999. "Derivation by Phase". Ms. Cambridge, Mass.: MIT Press.
- Cinque, G. 1999. *Adverbs and Functional Heads*. Oxford University Press.
- Di Sciullo, A. M. 1993. "On the complement domain of a head at morphological Form". *Probus* 5: 95-125.
- Di Sciullo, A. M. 1995. "X' selection". In *Phrase Structure and the Lexicon*, J. Roorick and L. Zaring (eds), Kluwer
- Di Sciullo, A. M. 1996a. "Atomicity and relatedness in configurational morphology". In *Configurations*, A.-M. Di Sciullo (eds), Cascadilla Press.
- Di Sciullo, A. M. 1996b. "Modularity and x⁰/xp asymmetries". *Linguistic Analysis* 26: 1-26.
- Di Sciullo, A. M. 1997a. "On word structure and conditions". In *Projections and Interface Conditions*, A.-M. Di Sciullo (eds): Oxford University Press, 3-27.
- Di Sciullo, A. M. 1997b. "Prefixed verbs and adjunct identification". In *Projections and Interface Conditions*, A.-M. Di Sciullo (eds), Oxford University Press, 52-73.
- Di Sciullo, A. M. 1999a. "Verbal structure and variation". In E. Trevino & J. Lema (eds.). *Semantic Issues in Romance Syntax*. Amsterdam Philadelphia: John Benjamins. Pp. 39-57.
- Di Sciullo, A. M. 1999b. *The Local Asymmetry Connection* 35. MITWPL.
- Di Sciullo, A. M. in press. "The asymmetry of morphology." In *Many Morphology*, P. Boucher (eds), Cascadilla Press.
- Di Sciullo, A.M. Forthcoming. *Asymmetry in Morphology*. MIT Press Monograph.
- Di Sciullo, A. M. and Tenny C. 1997. "Modification, event structure and the word/phrase asymmetry". In *NELS* 28.
- Di Sciullo, A. M. and Williams, E. 1987. *On the Definition of Word*. Cambridge, Mass.: MIT Press.
- Epstein, S. 1995. *The Derivation of Syntactic Relations*. Ms. Harvard University.
- Fong, S. 1991. Computational properties of principle-based grammatical theories. PhD thesis, Artificial Intelligence Laboratory, MIT.
- Grimshaw, J. 1990. *Argument Structure*. Cambridge, Mass.: MIT Press.
- Hale, K. and Keyser, S. J. 1993. "On argument structure and the lexical expression of syntactic relations". In *The View from Building 20*, K. Hale and S. J. Keyser (eds), Cambridge, Mass.: MIT Press.
- Hale, K. and Marantz, A. 1993. "Distributed morphology and the pieces of inflection". In *The View from Building 20*, K. Hale and S. J. Keyser (eds), Cambridge, Mass.: MIT Press.
- Kayne, R. 1994. *The Antisymmetry of Syntax*. Cambridge, Mass.: MIT Press.
- Knuth, D. E. 1965. "On the translation of languages from left to right". *Information and Control*, 8 (6), 607-639.
- Law, P. 1997. "Modularity in nominalizations". In *Projections and Interface Conditions*, A.-M. Di Sciullo (eds), Oxford University Press.
- Lieber, R. 1992. *Deconstructing Morphology*. University of Chicago Press.
- Pesetky, D. M. 1995. *Zero Syntax: Experiencers and Cascades*. Cambridge, Mass.: MIT Press.
- Reuland, E. 1997. "Deriving c-command in binding". In *NELS* 18.

- Robert, F. and Vijayashankar, K. 1995. "C-command and grammatical primitives". In *GLOW Newsletter*.
- Williams, E. 1981. "Argument structure and morphology". *Linguistic Review*, 1: 81-114.
- Williams, E. 1994. *Thematic Structure in Syntax*. Cambridge, Mass.: MIT Press.